



MAGNA-LOCK **Cork Inspire Natural**

FLOORING

Magna-Lock™ is the inspiring family of finishes that uniquely enables a full range of design options in raised access floor applications. Designers can now choose from wood and cork look manufactured by a world-class flooring company to bring their creative design ideas to life. With Magna-Lock™ Cork, designers can take their space to the next level with great design aesthetics, providing a unique comfort, impact resistant, sound absorbing, and highly sustainable finish.



Magna-Lock™ Cork Inspire Natural Features

- **Enhanced Design:** Magna Lock™ Cork Inspire flooring takes space to the next level.
- **Noise Mitigation/Impact Resistance :** Magna-Lock™ Cork is a natural sound absorber and offers unique comfort, absorbing heel impact. It also reduces the risk of objects breaking when accidentally dropped.
- **Sustainability/Healthy:** Magna-Lock™ Cork improves health, eliminates PVC and is Carbon Negative.

Sustainability Features	Product Offering	
	Wood Inspire	Cork Inspire
VOC Free	Green Guard Gold	Green Guard Gold
PVC Free	Blue Angel	Blue Angel
Indoor Air Quality	Blue Angel	Blue Angel
Environmental Performance	BREEAM (up to 8 point)	BREEAM (up to 8 points)
Material Transparency	LCA and EPD Available	LCA and EPD Available
Carbon Footprint (cradle to grave)	Plus 3.54	Plus 5.42
Carbon Balance (sequestration)	-101	-93

TECCRETE WITH STEEL TOPSHEET

MAGNA-LOCK™ SYSTEM

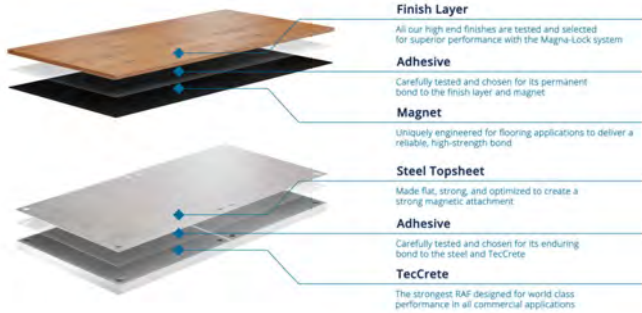

PERFORMANCE DATA

Material Properties	TC 1250	TC 1500
Concentrated Load (min)	1250 psi	1500 psi
Uniform Load (min)	600 psf	700 psf
Rolling Load (10/10,000 Pass)	1300 lbs /900 lbs	1500 lbs /1250 lbs

TECCRETE WITH STEEL TOPSHEET FOR MAGNETIC FINISHES

An industry leader for over 30 years the TecCrete system is the original concrete surface panel. Paired with Steel topsheet for the Magna-Lock™ system, our trusted floor has become the leading choice for architects and developers who demand best in class performance, value, and beauty for their critical building systems

CORNER-LOCK SYSTEM

BOLTED STRINGER SYSTEM

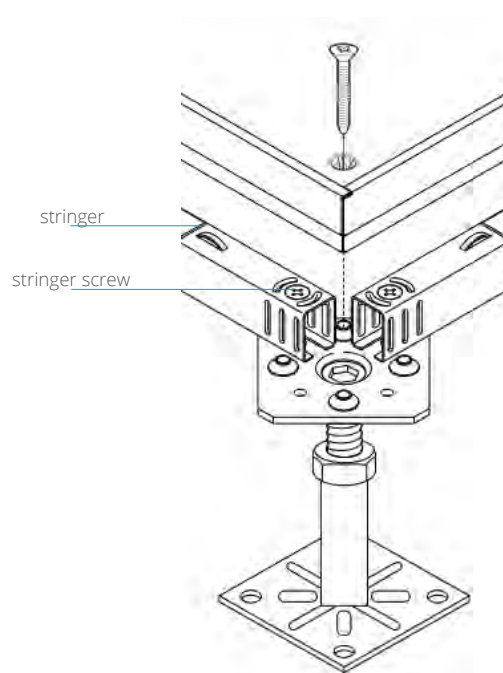
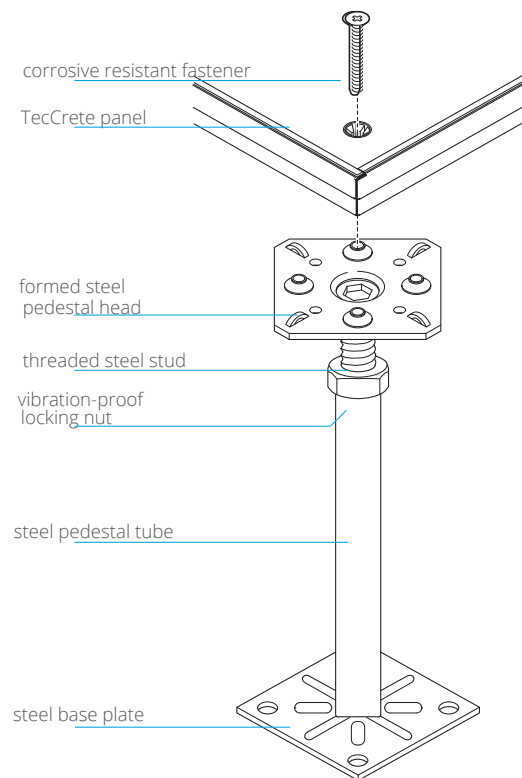

FEATURES

- **Raised Access Floor** designed to work with Magna-Lock™ Finishes.
- **Breaking the square** - Magna-Lock™ System facilitates many sizes, colors, finishes, textures and patterns.
- **Solid feel underfoot** and high level of acoustical performance
- **Industry leading** static and dynamic loading performance.
- **Laser leveled** finished floor.
- **Optimized** for underfloor air and modular power distribution.
- **Easy to install:** A special magnet applied to the back of the finished floor surface attaches to a Global IFS steel top sheet panel.
- **Easy to change:** Magna-Lock™ finishes can be quickly removed and relocated with minimal effort and no waste.
- **Quick to install:** Magna-Lock™ finishes can be installed quickly just before occupancy, eliminating construction related damage.

MAGNA-LOCK CORK DETAILS



Magna-Lock Cork finishes display slight variation in color and pattern between tiles.

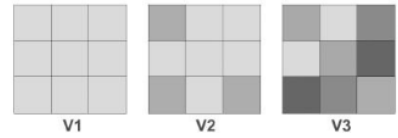

Inspire Natural Cork



Fashionable Cement

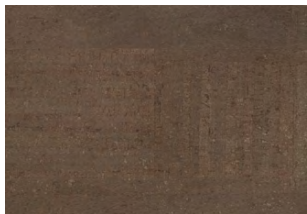

Fashionable Graffiti



Identity Chestnut



Identity Moonlight



Shell Marfim



Originals Harmony



Originals Shell



Traces Jasmin



Traces Spice

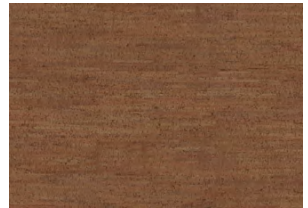

Traces Tea